



VES MAXX
12L/24L



**TRUE DC !
VARIABLE SPEED COMPRESSORS !**

When you need maximum cooling with maximum efficiency the VES MAXX Deluxe system is the answer. The MAXX is a 3 component system that utilizes 2 of our variable speed DC Compressors set up in a tandem configuration. The MAXX evaporator allows the evaporator to be built into a cabinet or mounted on the ceiling. This system is ideal for large commercial applications and extreme climates.

Deluxe Features:

- 6 large 4" rotatable vents with powder coated fascia for quieter and direct able air flow
- Adjustable Compressor baseline for adjusting current consumption and BTU output
- Always active Eco Mode
- Included manual control with infinite variable speed blower control
- Thermostat ready for all of our optional thermostat options

Specifications:

VES MAXX 12L

Voltage Range 10-15 VDC

Current Consumption 75-95 AMPS @ 12 Volts VDC*

18k BTU

VES MAXX 24L

Voltage Range 20-31 VDC

Current Consumption 50-65 AMPS @ 24 Volts VDC*

19k BTU

*Current ratings are nominal. Current ratings can fluctuate depending on accessories and or operating conditions. XXL condenser is recommended for climates over 100 degrees Fahrenheit. Dual fan condenser with 11" fans cannot be wired in series, maximum air flow is recommended for this condenser so parallel wiring is recommended. All specifications and features are subject to change without notice.

VES MAXX

This diagram shows a typical set up with the large MAXX Evaporator up high above the back doors in a van. The MAXX Evaporator is rated at a powerful 600 cfm so the cold air will travel the length of a large enclosure and the cold air will fall. The MAXX Evaporator can be built into a cabinet or an enclosure can be built to hide it as long as return air can enter the back of the unit and the cold air can leave the front.

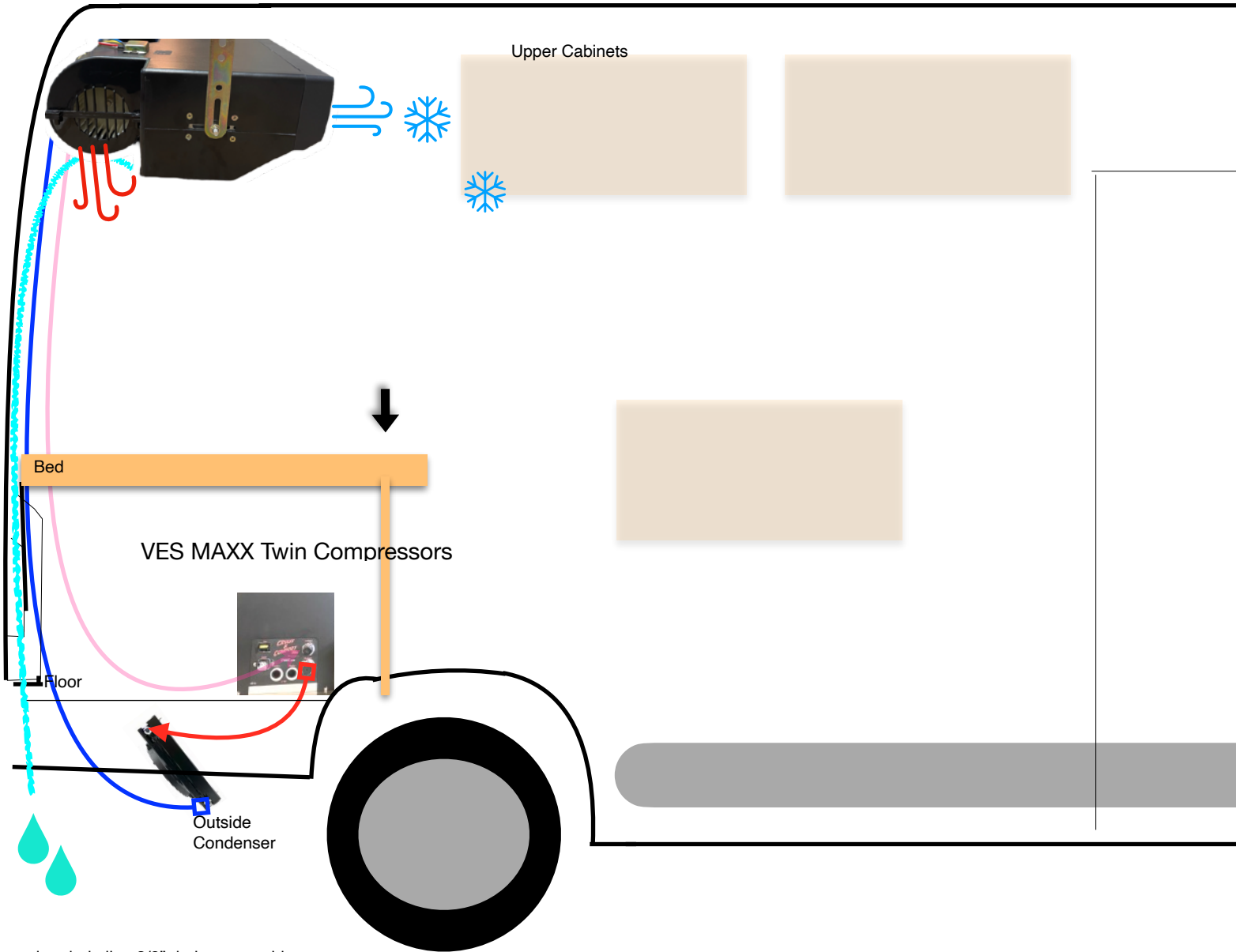

Condensation drain line 3/8" drains to outside

MAXX Evaporator Specifications

Weight: 21 lbs (includes mounting brackets)

Maximum Air Volume 600 CFM

600 CFM !!



Top View

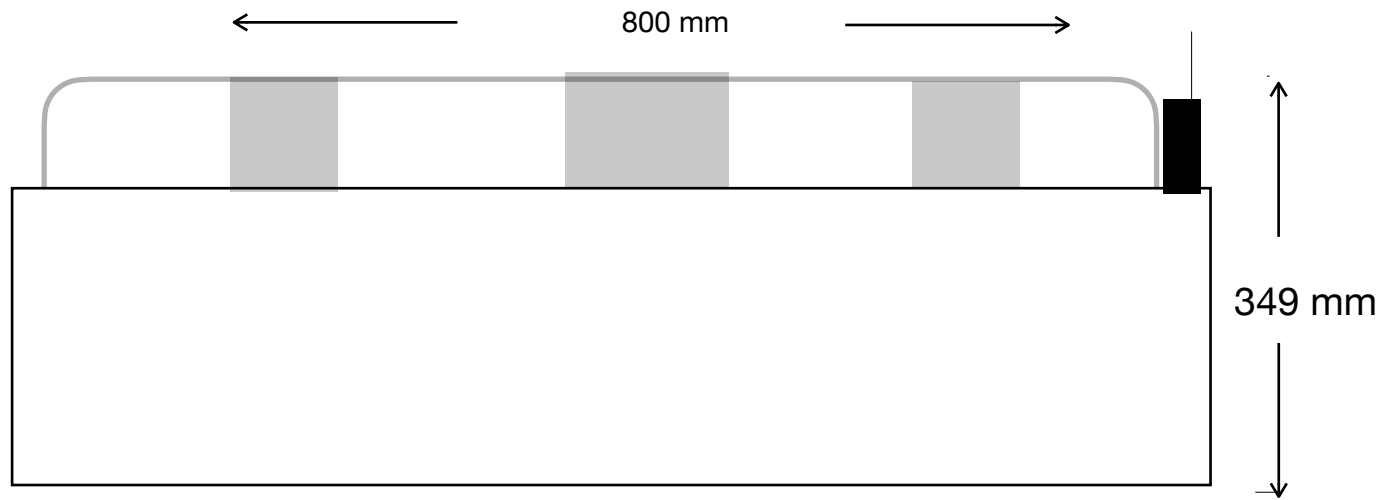

Front View

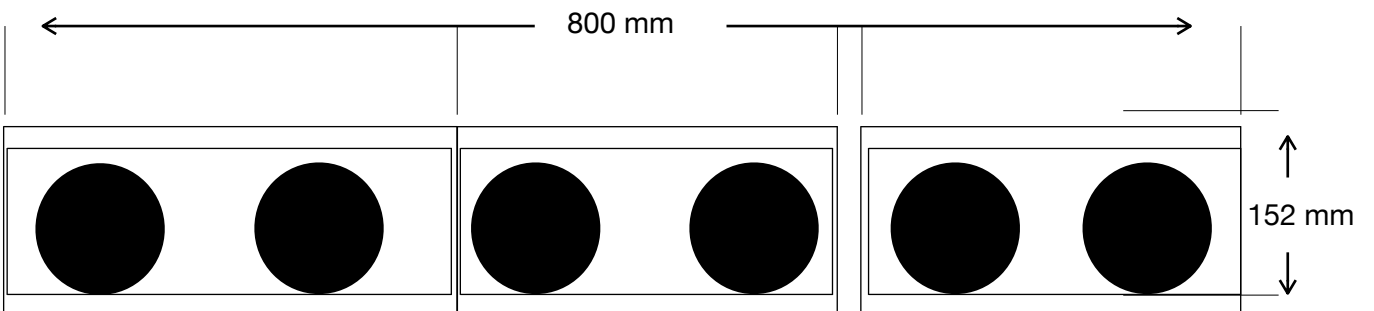

Compressor Box Specifications

Weight : 57 lbs

Stainless Steel Chassis and Enclosure

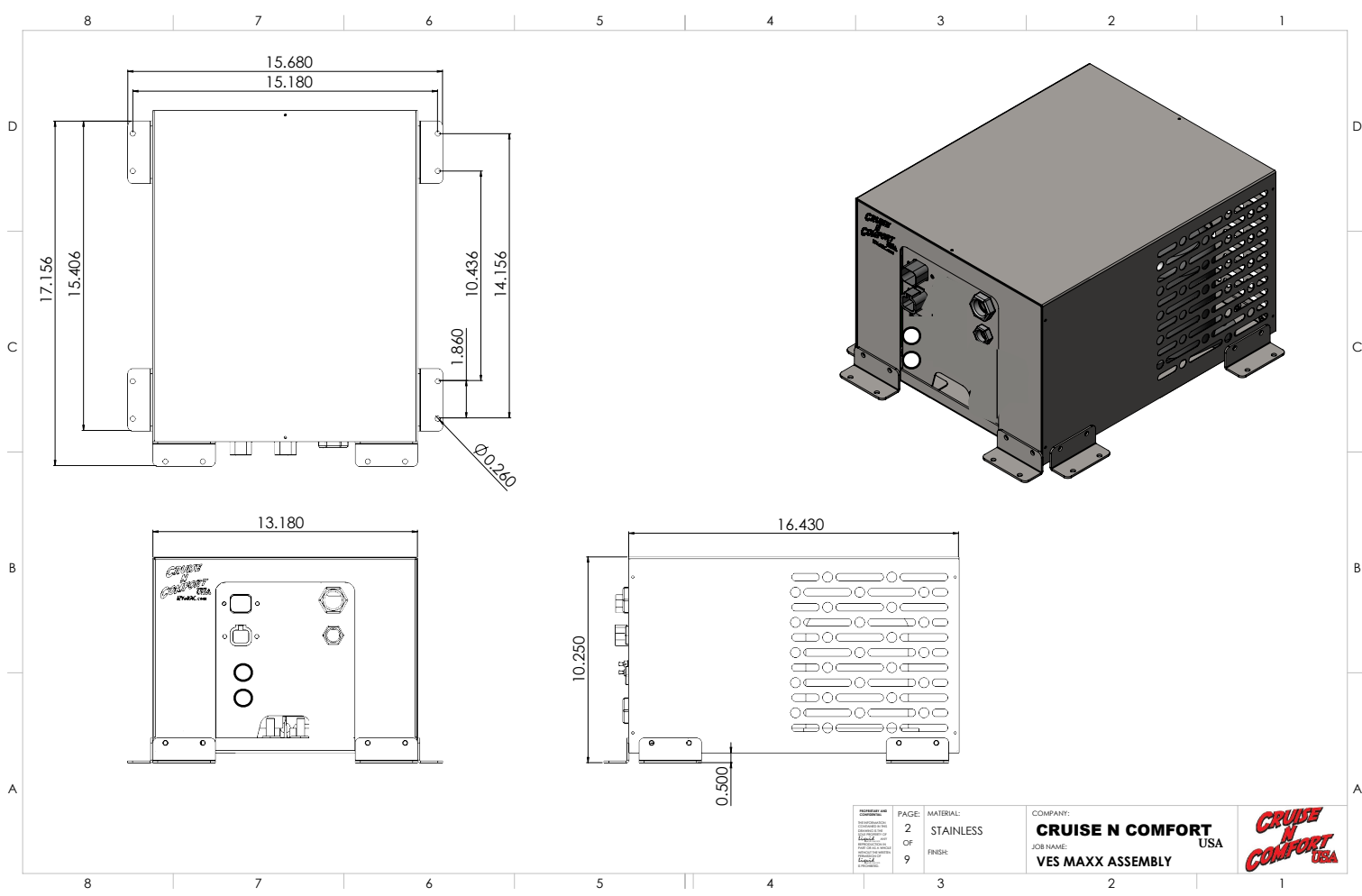

Dual Fan Extreme Climate Condenser Specifications

Salt resistant powder coated aluminum construction. When using this condenser on MAXX units it cannot be wired in series. Maximum air flow is recommended for this condenser so parallel wiring is recommended.

11" IP68 performance fans

Weight:
Condenser, Fan Shroud, 2 fans 11.72 lbs

Rock Guard 2.11 lbs

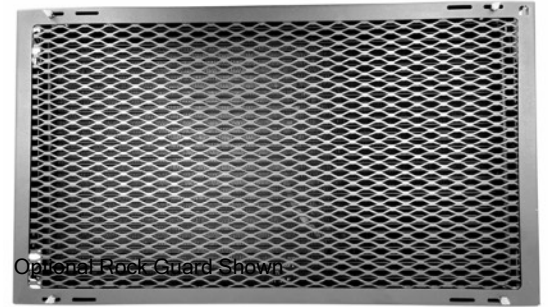

Optional Rock Guard and Stainless Condenser Brackets Shown

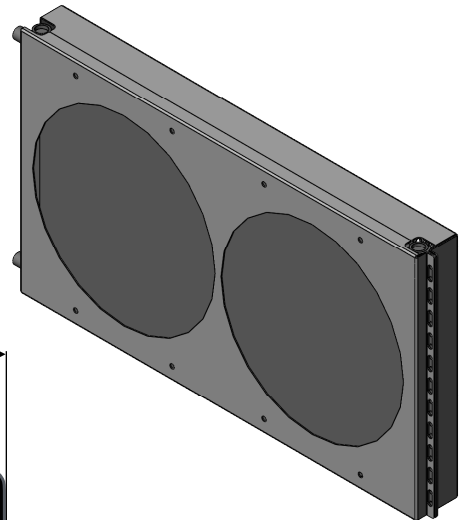
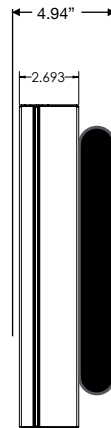
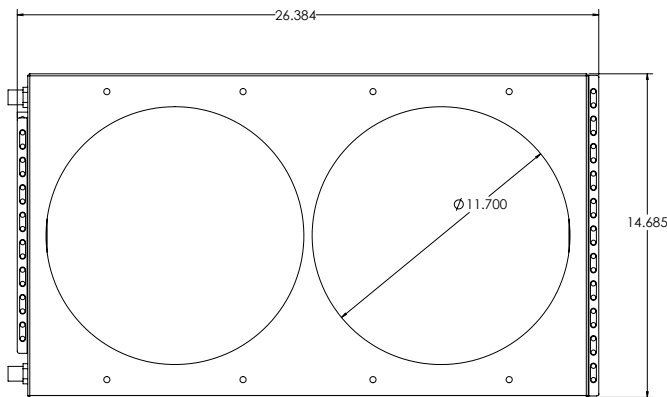
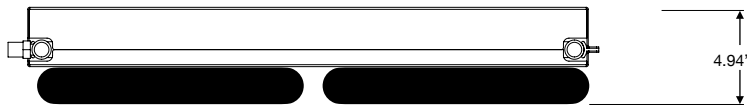

Optional Dual Fan XXL Extreme Climate Condenser

Salt resistant powder coated aluminum construction
 16" IP68 performance fans.

Weight:
 29.4 lbs

Includes: Condenser, Fan Shroud, 2 fans and included Rock Guard

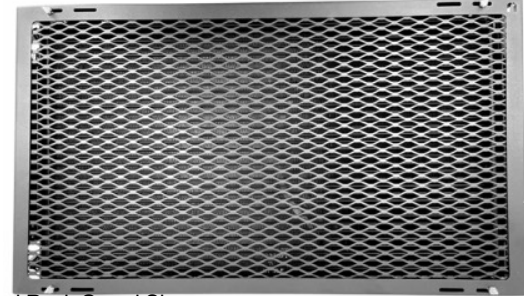

Optional Rock Guard Shown



Optional Rock Guard and Stainless Condenser Brackets Shown

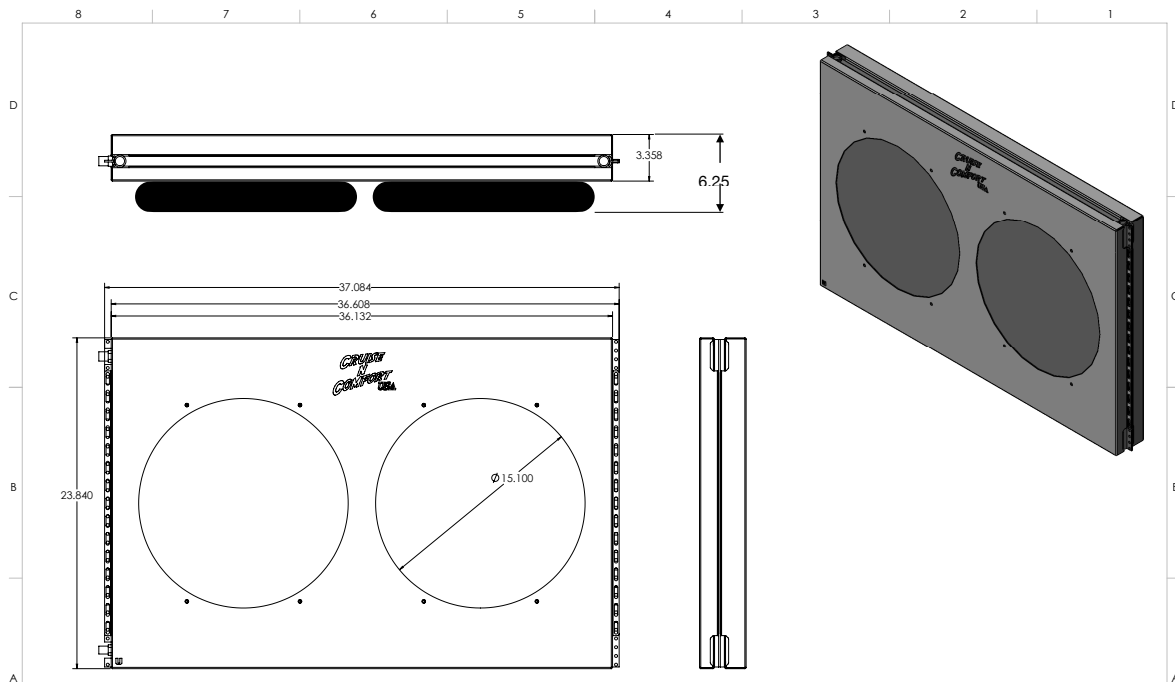

CRUISE N COMFORT USA

1020 West Ranch Road Suite 102 Tempe, AZ 85284
 Tel: 1(855)899-1442 Fax: 1(888)246-2832
 Email: info@CruiseNComfortUSA

Universal Condenser Mounting Brackets:

These mounting brackets are made of heavy Stainless Steel and include all stainless hardware. These brackets are universal and give you the ability to mount the condenser under, on top, or on the back of the vehicle. The brackets are completely adjustable.

Weight: 3.1 LBS



*optional rock guard shown



Condenser Rock Guard:

The CNC Rock Guard is designed to help protect our condensers from rocks and debris. This option is available for all of our condensers and come installed on the condenser when purchased at the time the condenser and main unit are ordered new. If you previously purchased a condenser from us it will fit, but we will need an email from you with the size of your condenser (single fan or dual fan). The unit is flat black powder-coated aluminum and resists salt and corrosion. Available for all of our condensers. Included on XXL condenser.

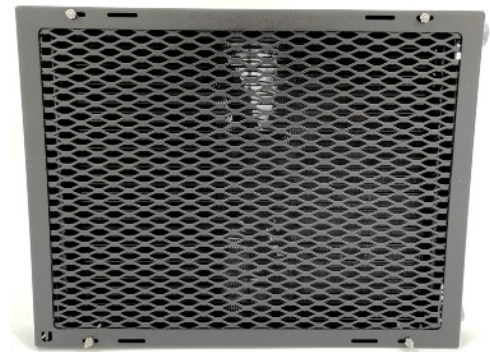

WiFi Thermostat Options

Unlike competitor's WiFi thermostats, which either require a cellular chip activated by a specific carrier or only offer direct WiFi connection to a cell phone like Bluetooth, our WiFi thermostats broadcast over the internet when connected to a 2.4 GHz network of your choice. These connections can be established through a cellular phone from almost any carrier, a tablet, a WiFi hotspot, or even Starlink satellite WiFi. You can leave the internet device in the vehicle, allowing the thermostat to maintain an internet connection. This enables you to connect to, view, and control your vehicle's temperature, and turn the unit on or off from anywhere using the app.

DT-04 WiFi App Enabled Thermostat:

Our new thermostat is app enabled and includes a WiFi connection and is prewired for our systems. Includes two PWM potentiometer with mounting plate for efficient blower control. Thermostat also has a heat function that can trigger a heating device (24 volt DC Relay required).
Available Colors: White (-W) or Black (-B)



*Wifi app compatible with internet hot spots and routers that

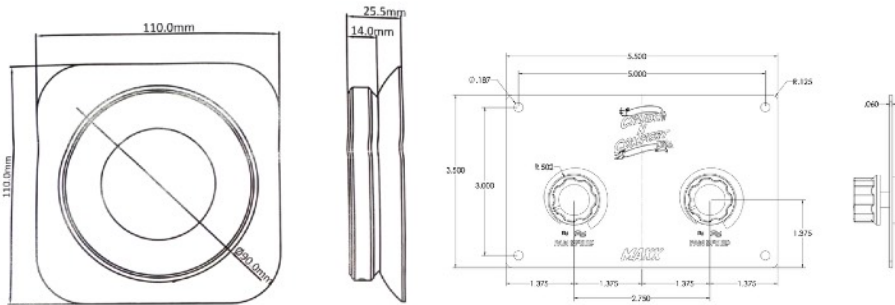

Thermostat Mounting Plate for DT-04-TP:

The DT-04-TP is an easy solution for mounting our DT-04 thermostats. We machine these brackets, powder-coat them and assemble them with our DT-04 thermostat.
Available Colors: White (-W) or Black (-B)

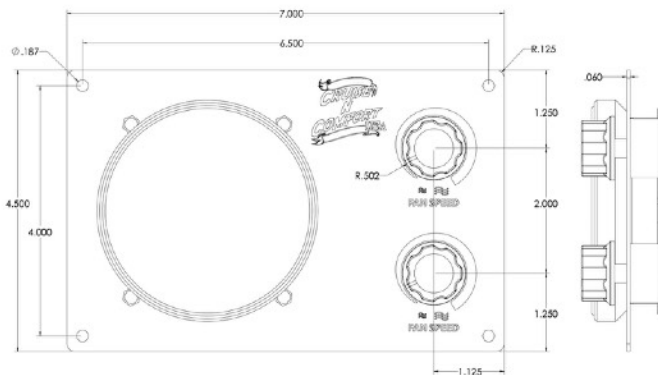

DT-05 WiFi App Enabled Thermostat:

Our new thermostat is app enabled with a customer supplied WiFi connection and is prewired for our systems. Includes two PWM potentiometers with mounting plate for efficient blower control. Thermostat also has a heating device (24 volt DC Relay required). Available Colors: White (-W) or Black (-B)



*Wifi app compatible with internet hot spots and routers that can

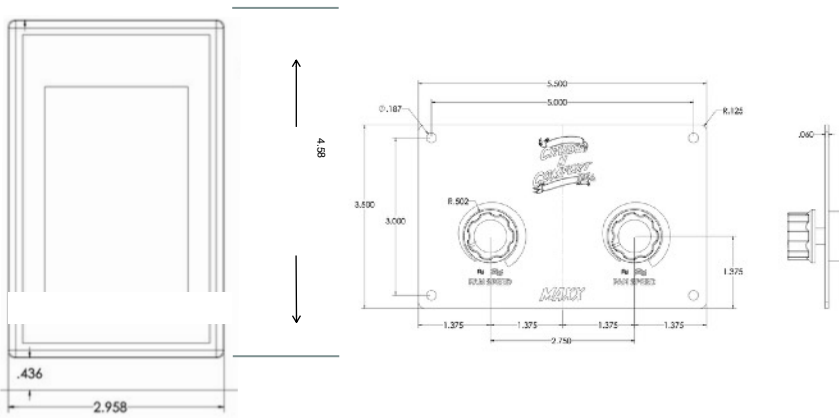

Thermostat Mounting Plate for DT-05-TP:

The DT-05-TP is an easy solution for mounting our DT-05 thermostats. We machine these brackets, powder-coat them and assemble them with our DT-05 thermostat. Available Colors: White (-W) or Black (-B)

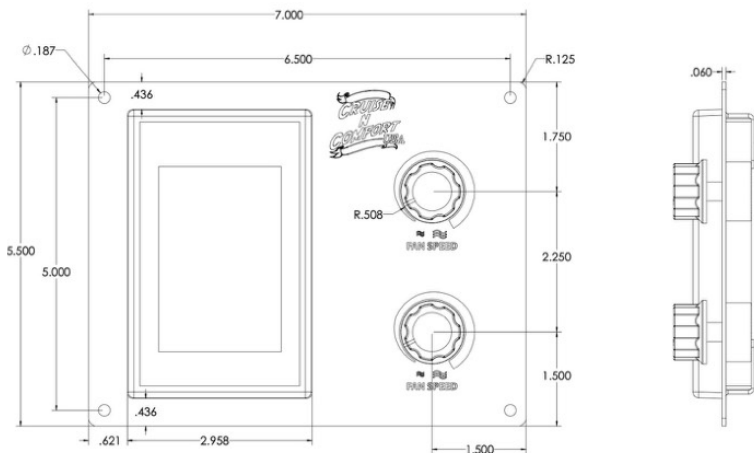

Optional Sensors for DT-05:

DT-OS Outdoor wired temperature sensor displays the actual outside temperature to the DT-05 thermostat. *
Cruise N Comfort sticker can be removed

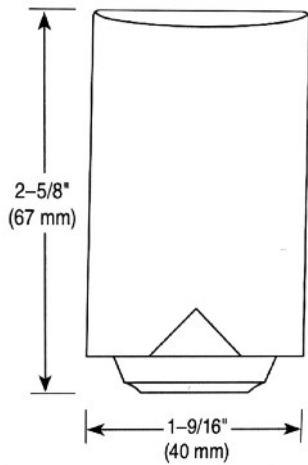

DT-IS Remote wired flush mount indoor sensor allows for temperature sensing in areas away from thermostat. The thermostat can then be set to take readings from the thermostat sensor, remote sensor or average between both.
*Cruise N Comfort sticker can be removed



Front View

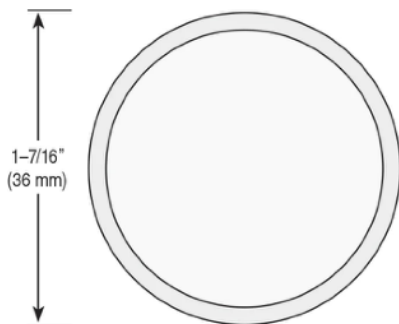

Side View

